

# Roof Lantern

## Installation Guide

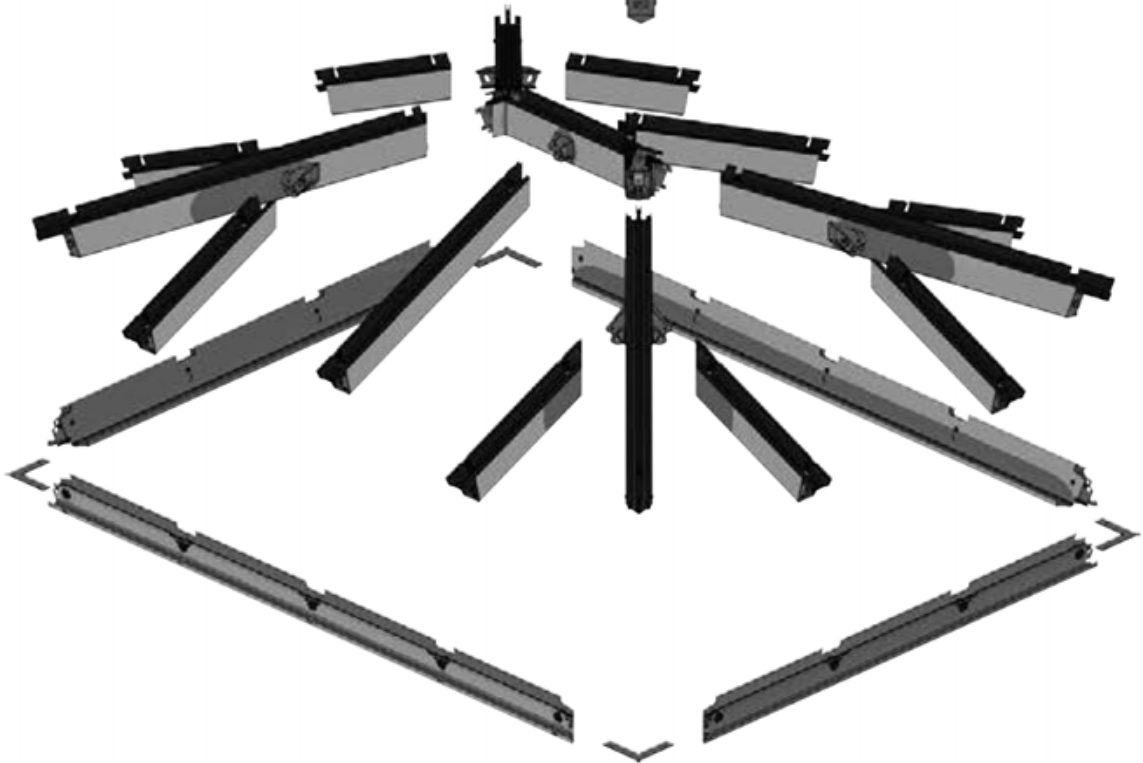

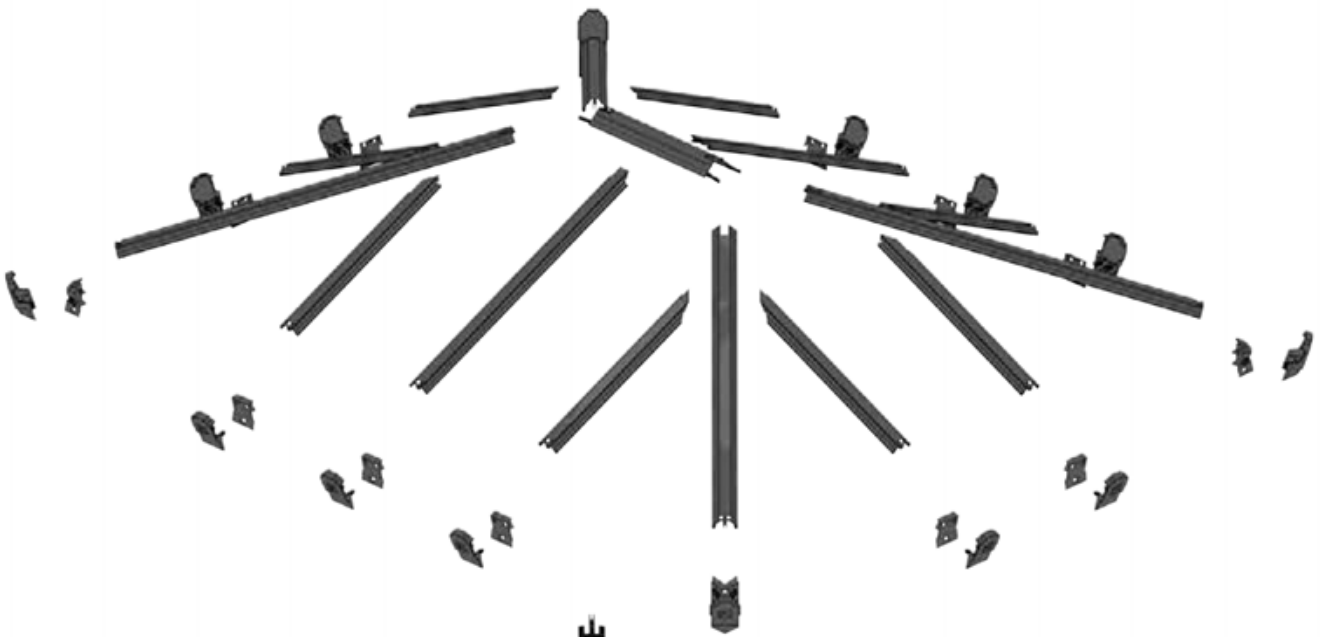
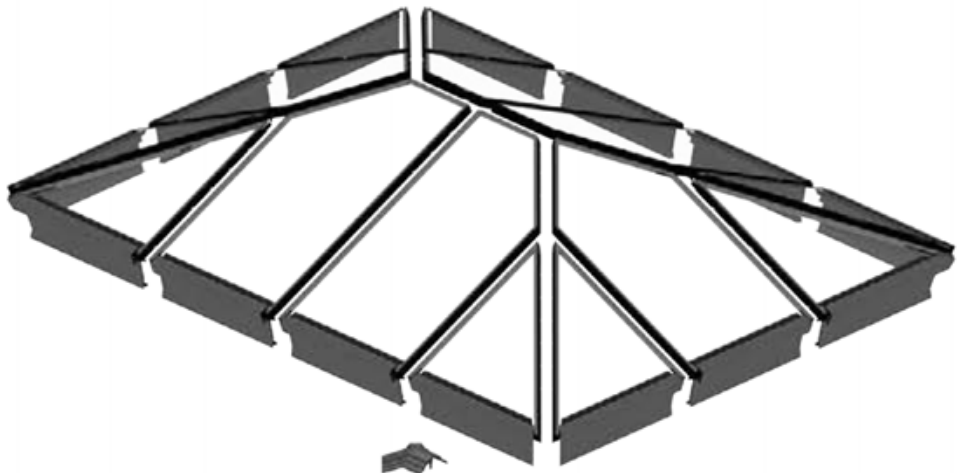

## TOOLS REQUIRED



Cordless  
Screwdriver



5mm Hex Bit  
(Supplied)

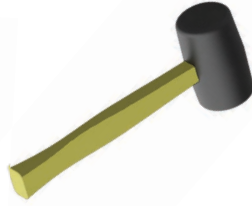

Soft  
Mallet



Wire  
Cutters



Sealant

## PACKAGING CONTENTS



Eaves Beams



Ridge



Hips



Rafters



5mm Hex Bit



Rafter Outer  
End Cap



Rafter Inner  
End Cap



Hip Outer  
End Cap



Hip Inner  
End Cap



Eaves Beam  
Corner Bracket



Boss Top Cap



M8x60mm  
Rafter Bolts



M8x70mm  
Hip Bolts



M8x20mm  
Isolating Collar  
Bolts



Tapered  
Washers



Ball  
Finial



4.8x63mm  
Eaves Beam  
Screws



Support  
Block



Fir Tree  
Clips



Tie-Wrap

# EAVES BEAM

1

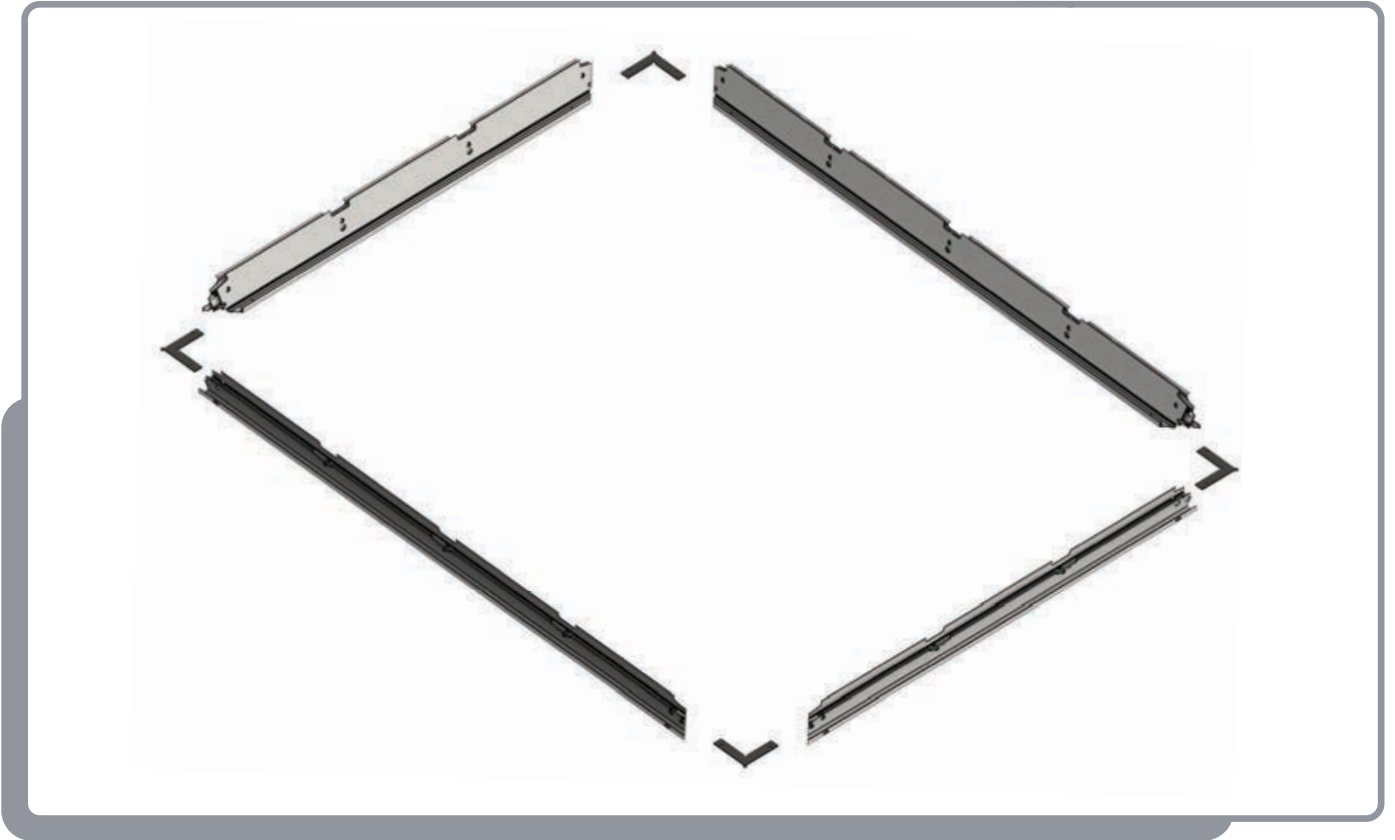
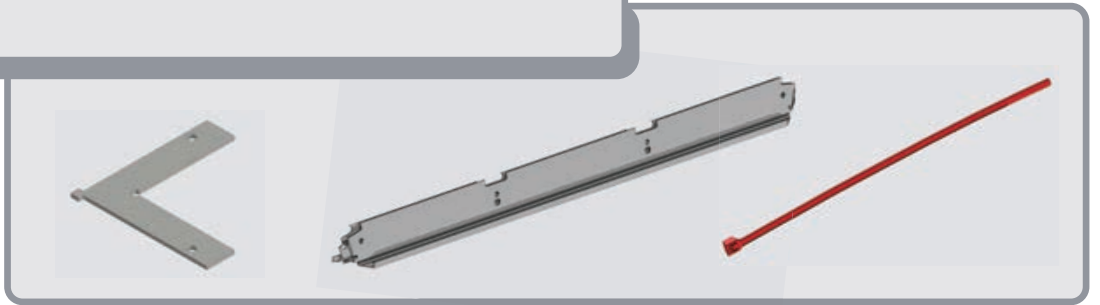

1 Slide together using corner brackets

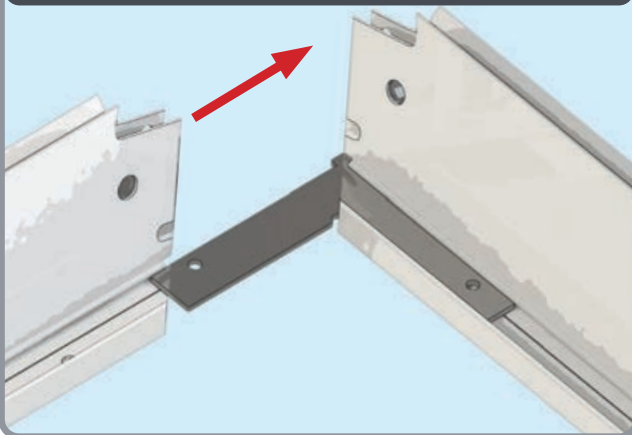

2 Temporarily secure corners with tie-wraps

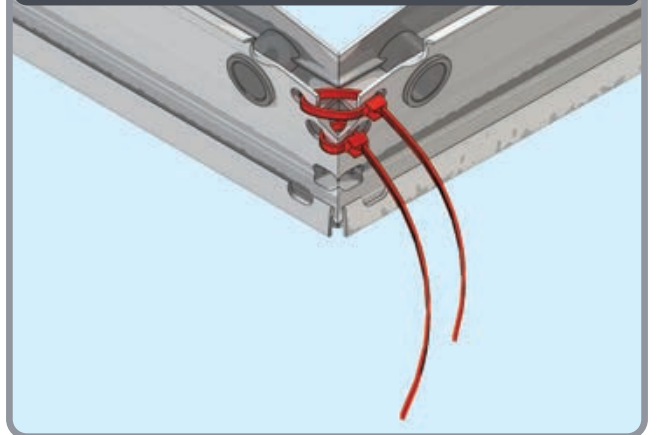

Ensure corner is closed up tightly

## APPLYING SEALANT

# 2



Apply sealant generously **ONLY** where shown

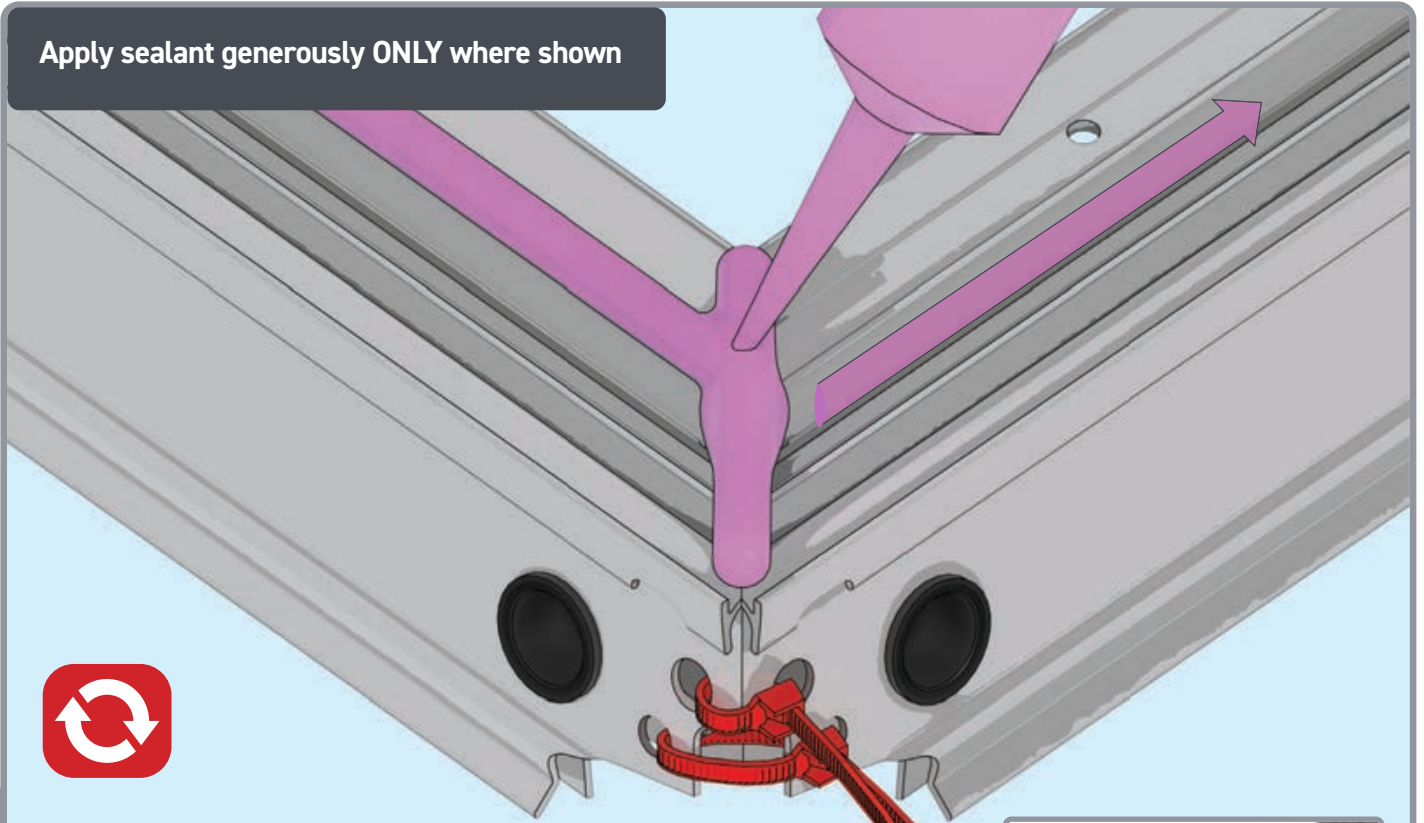

Corner position of sealant



- **DO NOT** screw down yet
- **Only** apply sealant where indicated



- **DO NOT** apply sealant to the gap between the upstand and the eaves beam, this will block the drainage

# SPIDER ASSEMBLY

3

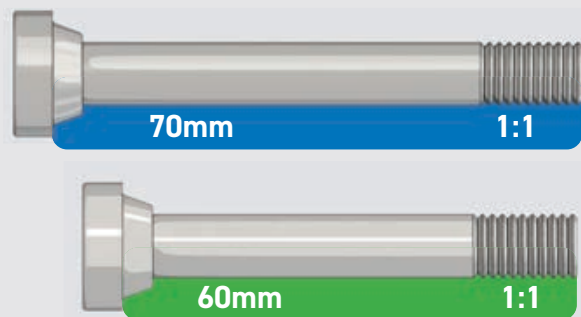

- 1 Secure hips to boss using 70mm bolts
- 2 Secure rafters using 60mm bolts

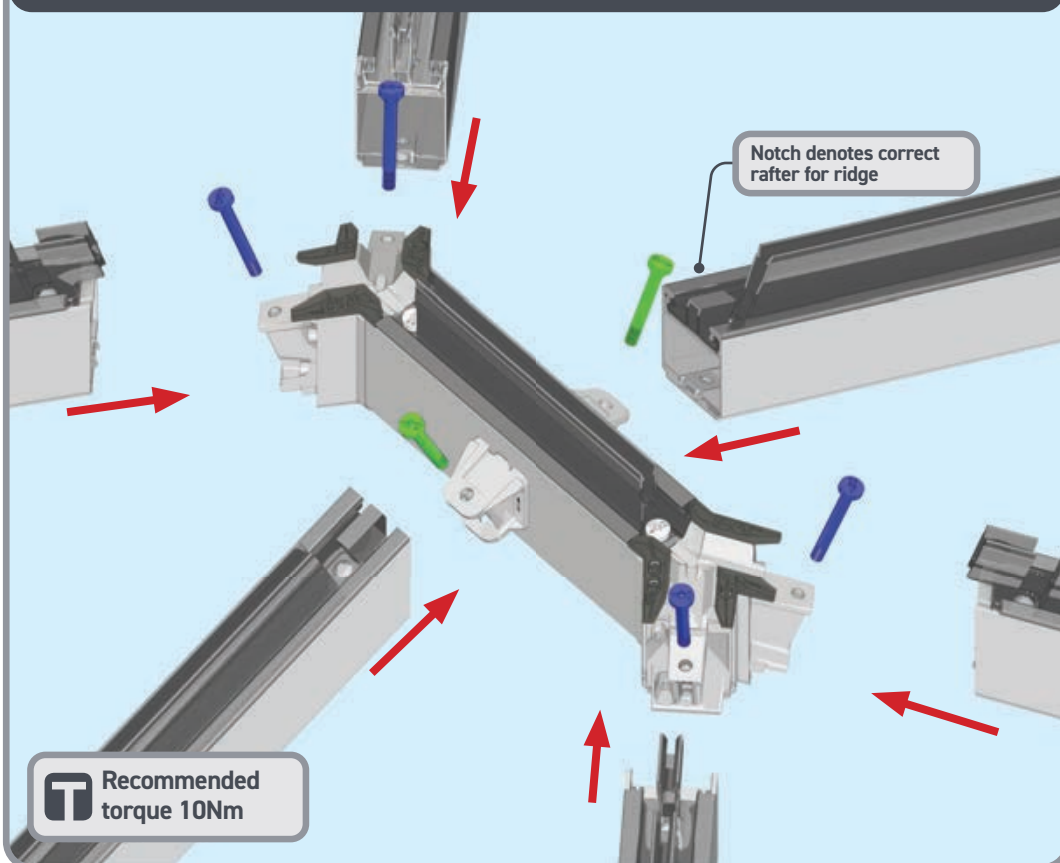

## Boss variations

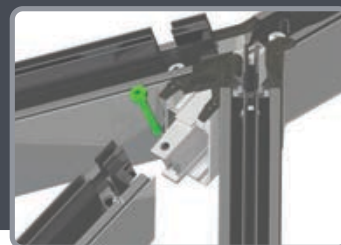
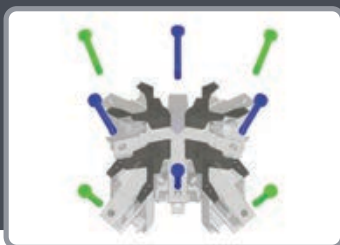

Ensure correct size bolts and tapered washers are used

## JACK RAFTERS (OPTIONAL)

4



- 1 Raise hip if needed 2 Rotate into position

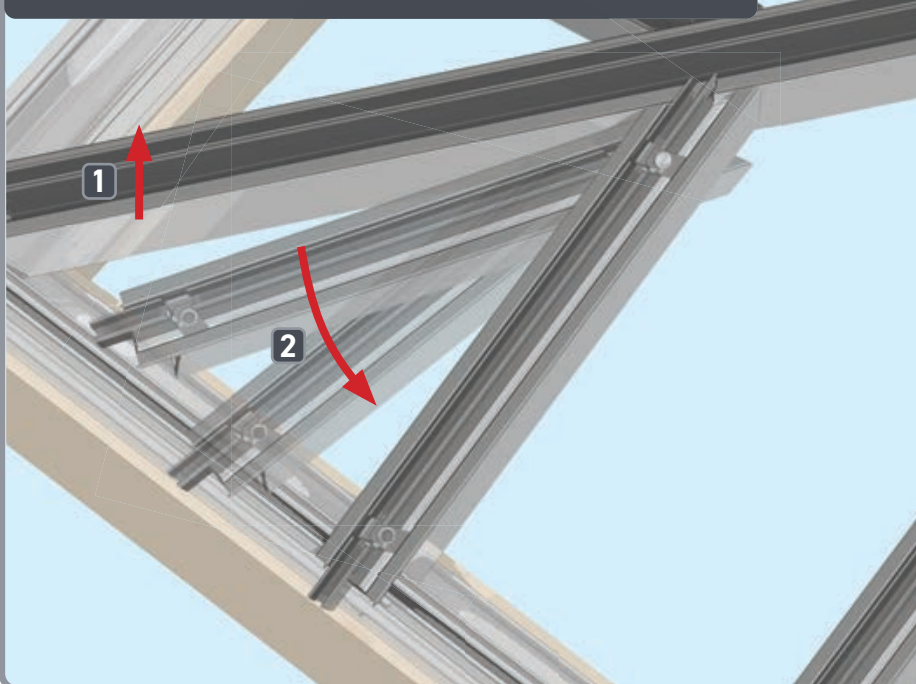

- 2 Secure using 60mm bolts

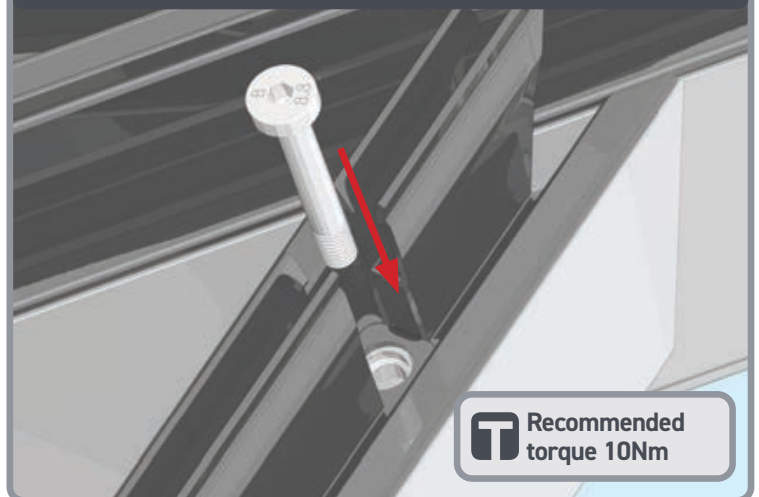

Ensure correct size bolts and tapered washers are used

# ATTACHING SPIDER

# 5

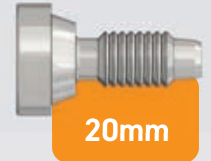

- 1 Loosely fit all 20mm bolts
- 2 Tighten bolts fully
- 3 Remove tie wraps

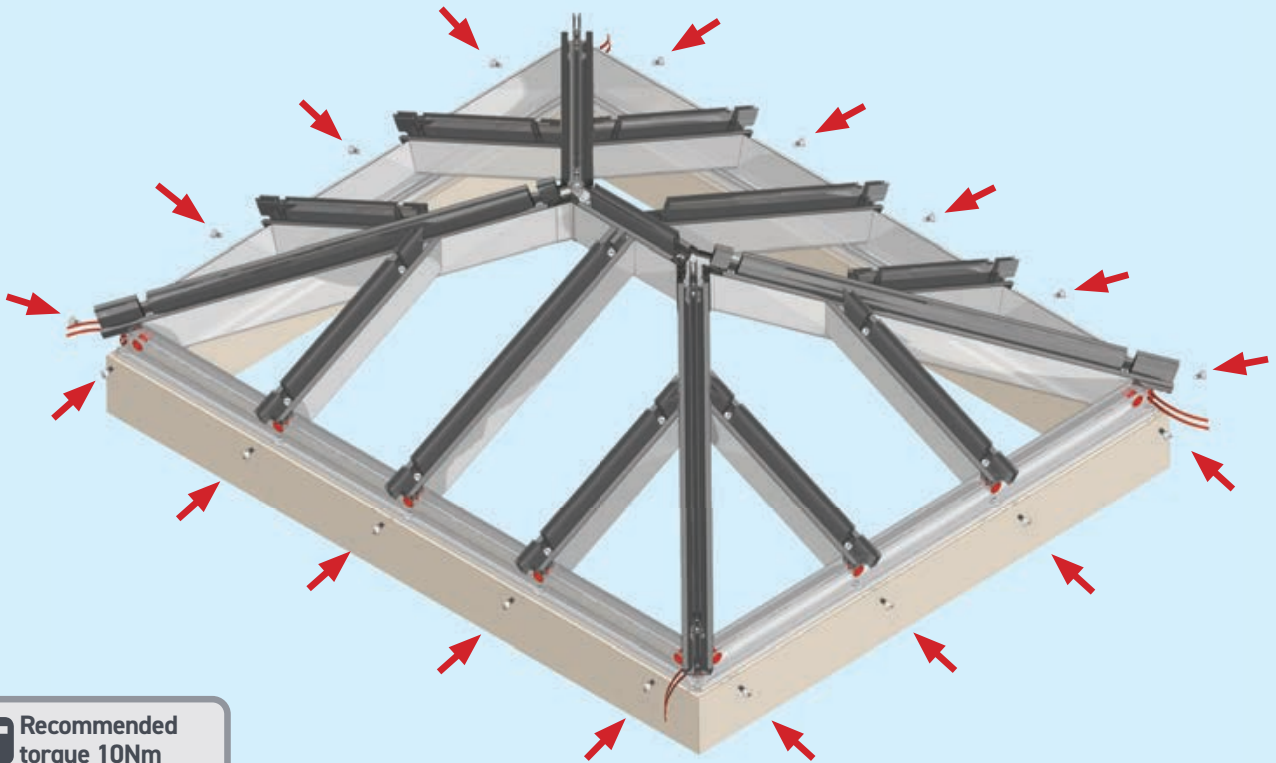

 Recommended torque 10Nm

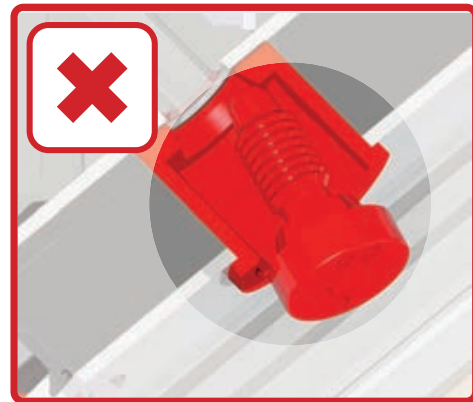
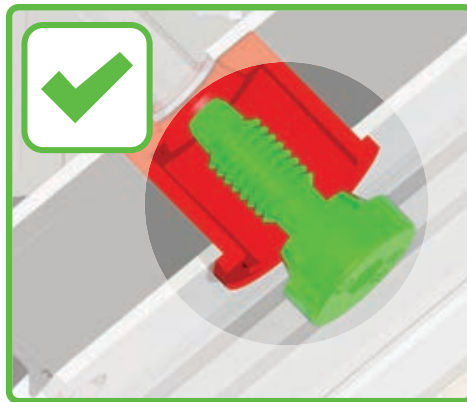

**BEWARE not to cross thread bolts when fastening**



## FIXING DOWN

# 6

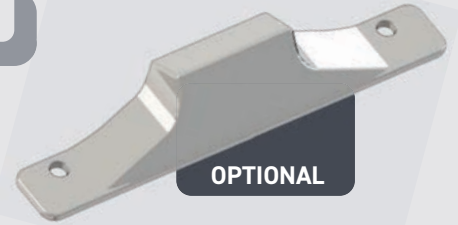

1 Position if supplied



2 Fasten down through pre-drilled holes

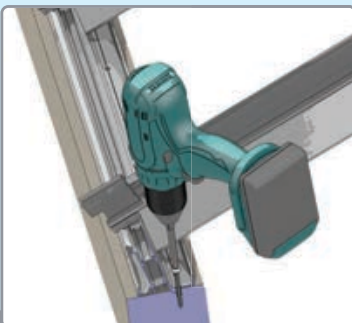
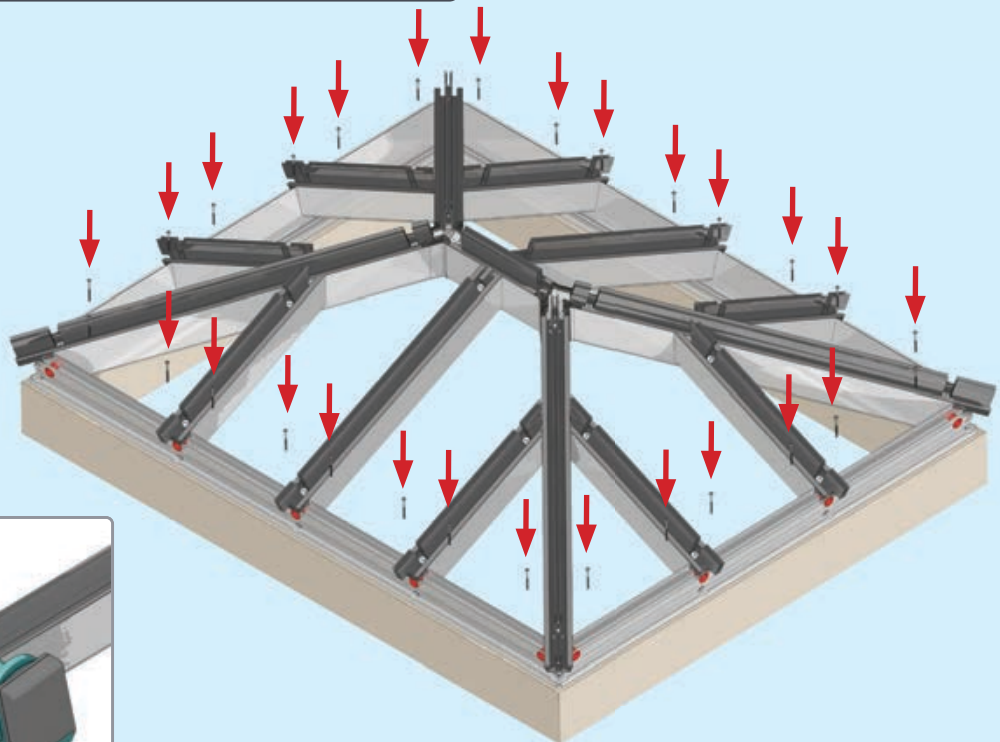

- USE packers under eaves beam to support each screw
- CHECK eaves beams are fully sealed to upstand

# GLASS RETAINER

# 7

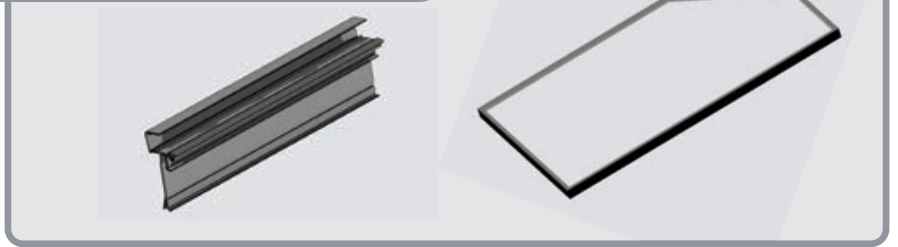

1 Slide glass into retainer

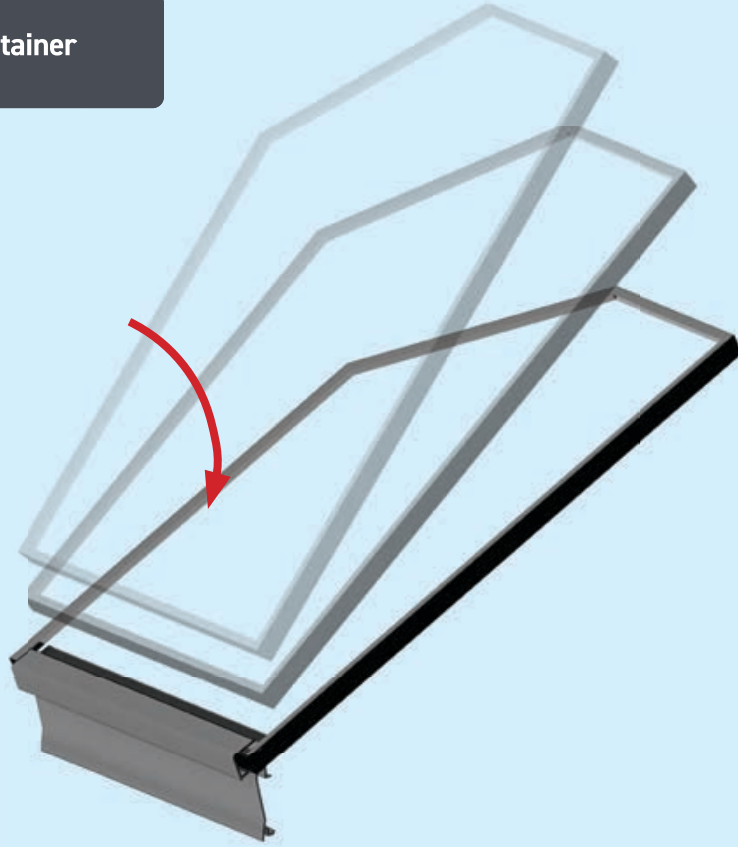

2 Set spacings as shown

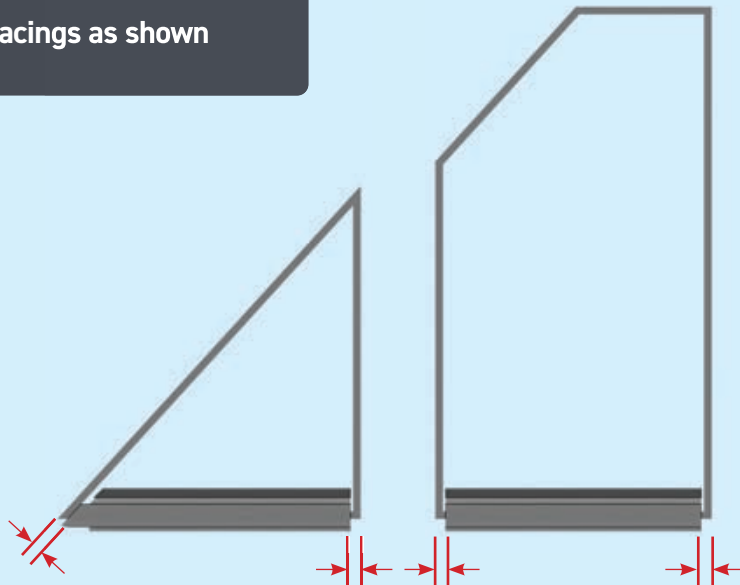

Dimensions shown  
approx 15mm

# GLAZING

8

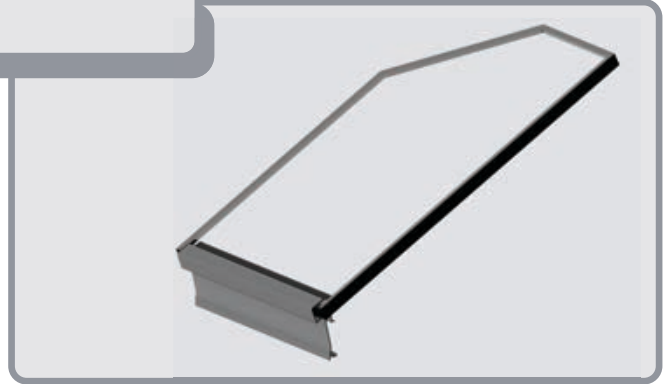

Locate top edge and rotate into position

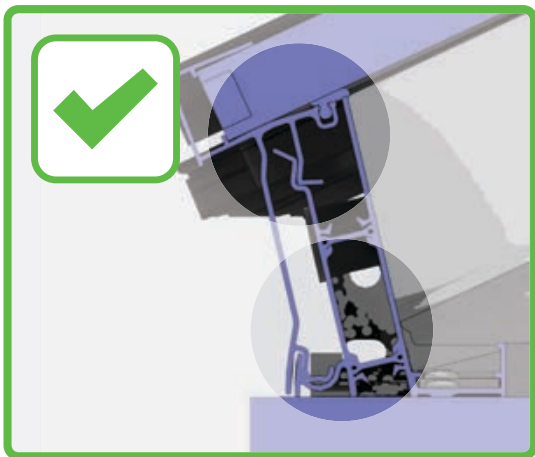
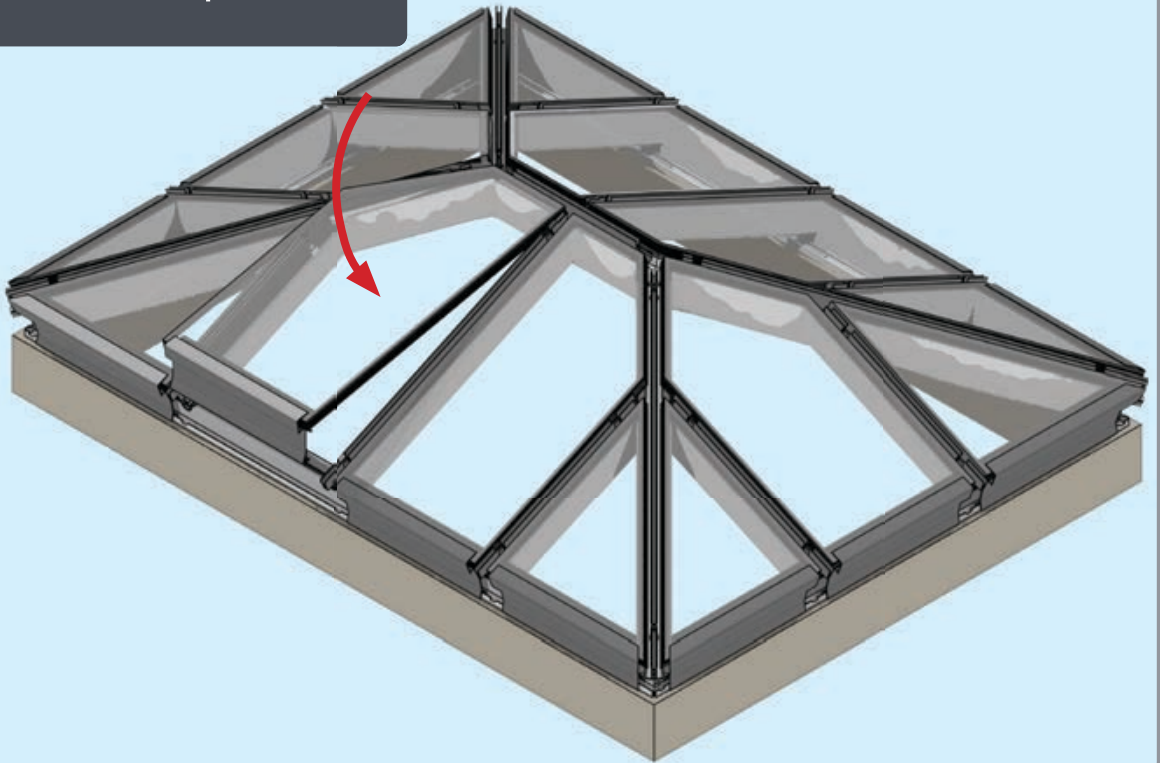

Ensure retainer is seated as shown

# HIP LOWER ENDCAP

9



1 Adjust glass retainer

2 Rotate into position

3 Use mallet to fit clips

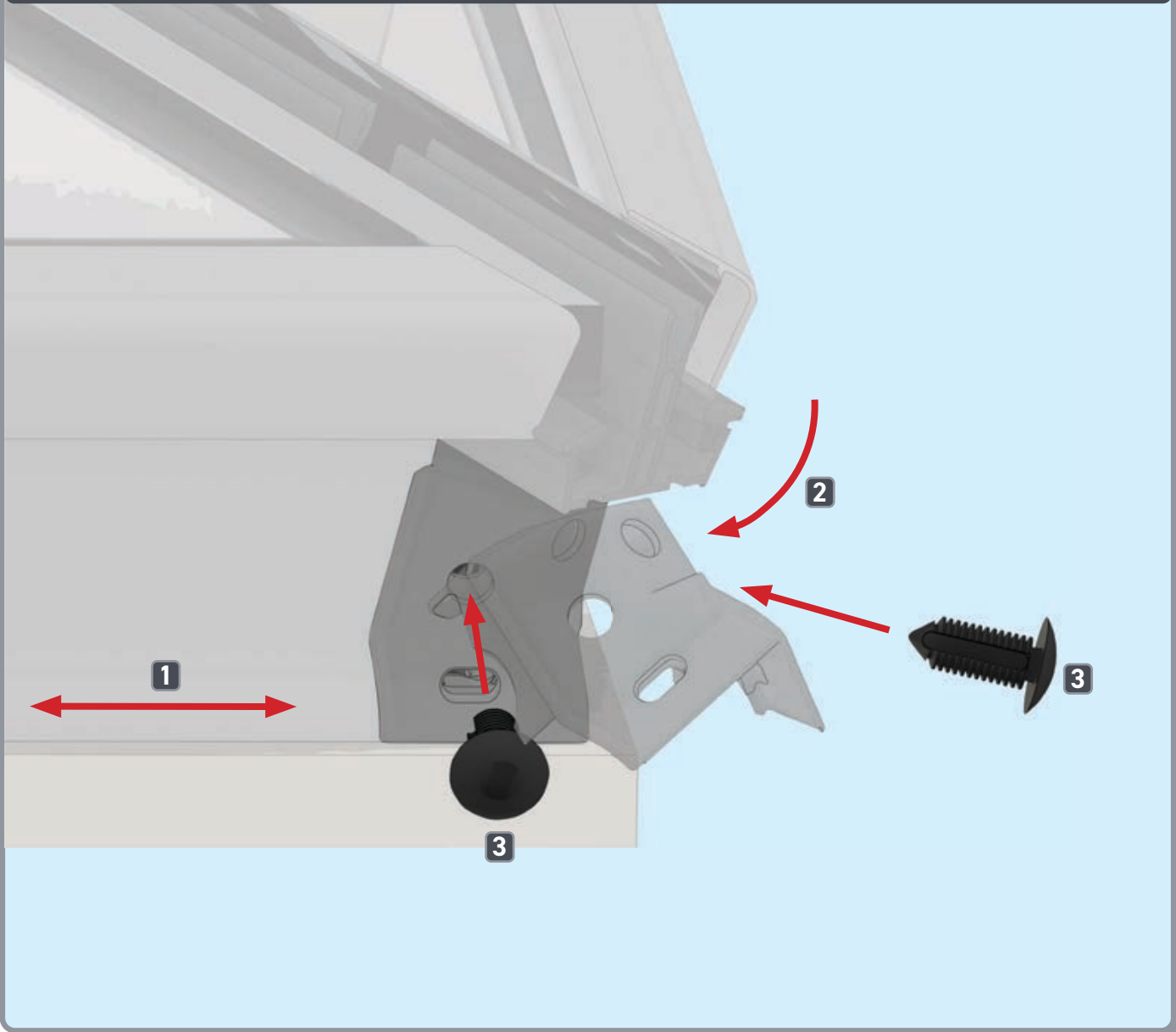

# LOWER RAFTER ENDCAPS

# 10

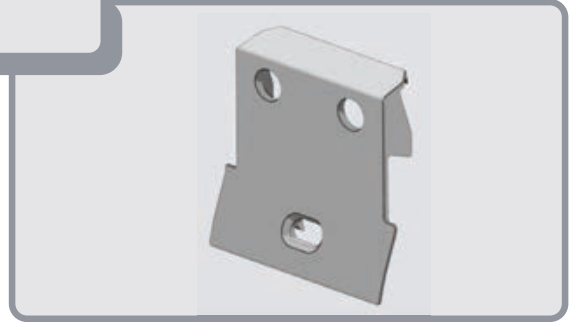

- 1 Adjust glass retainer
- 2 Rotate into position

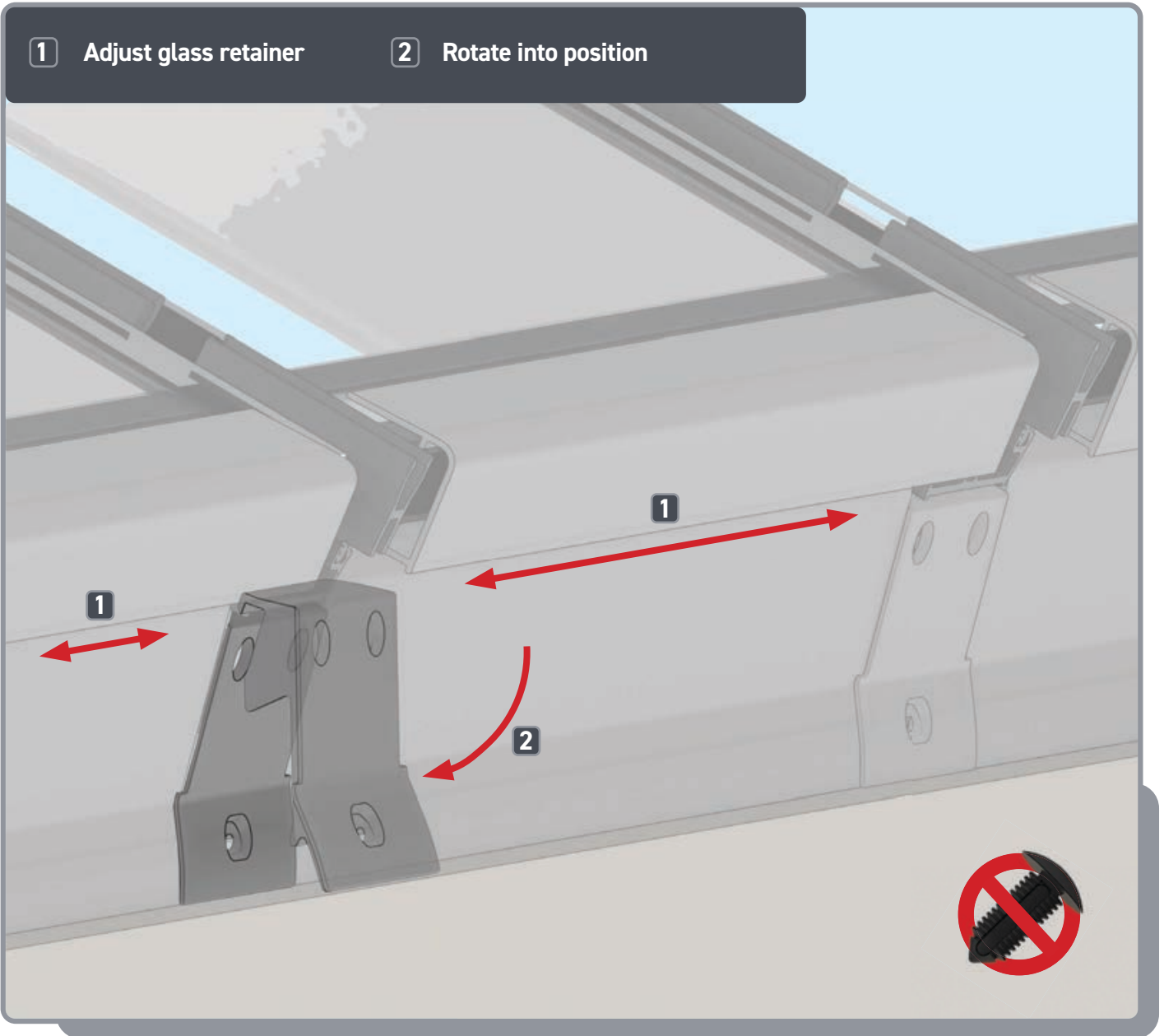

## RIDGE TOP CAP

11



Clip top cap on to ridge and space centrally

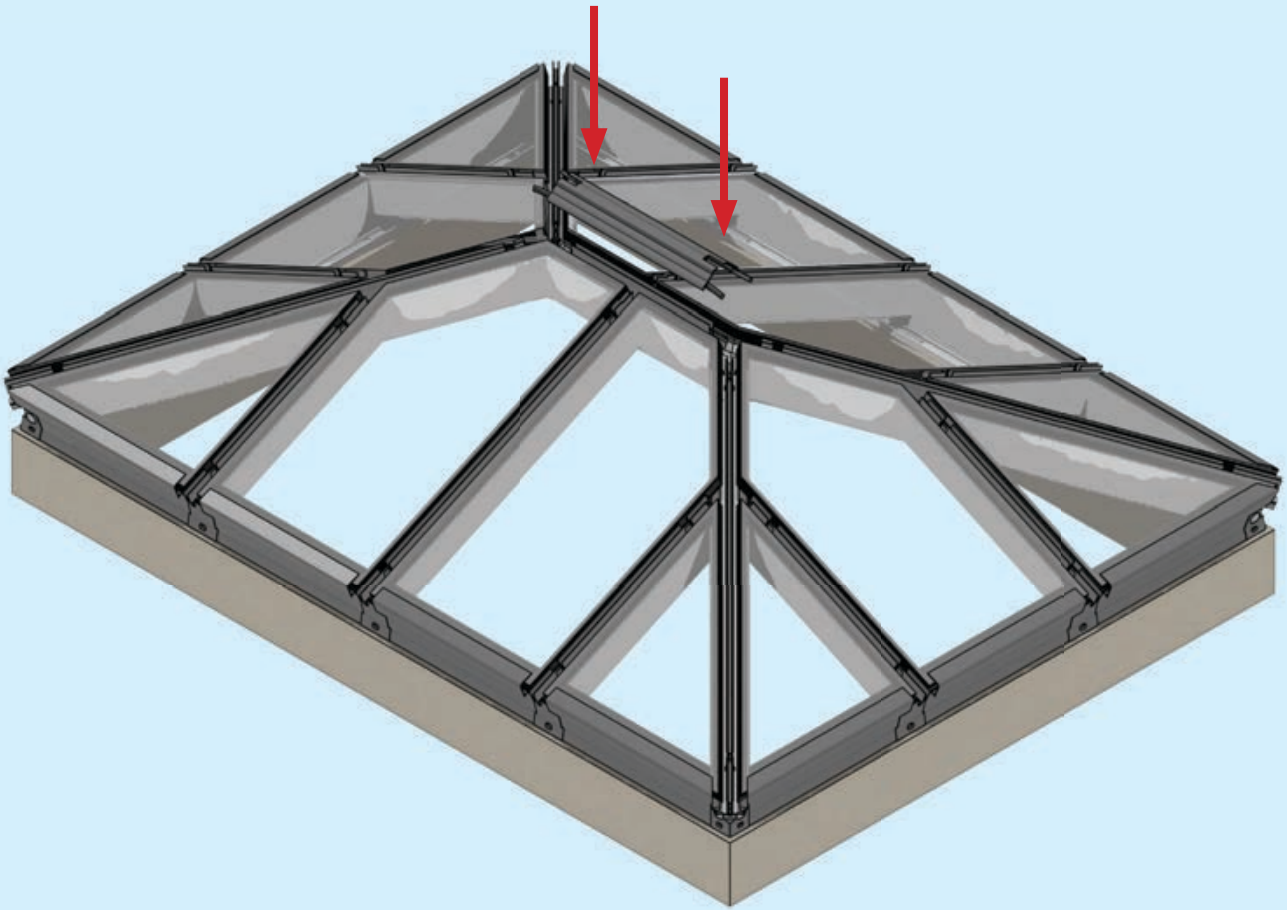

Leave gaskets overlong

## HIP TOP CAPS

12



Clip top caps on to hips

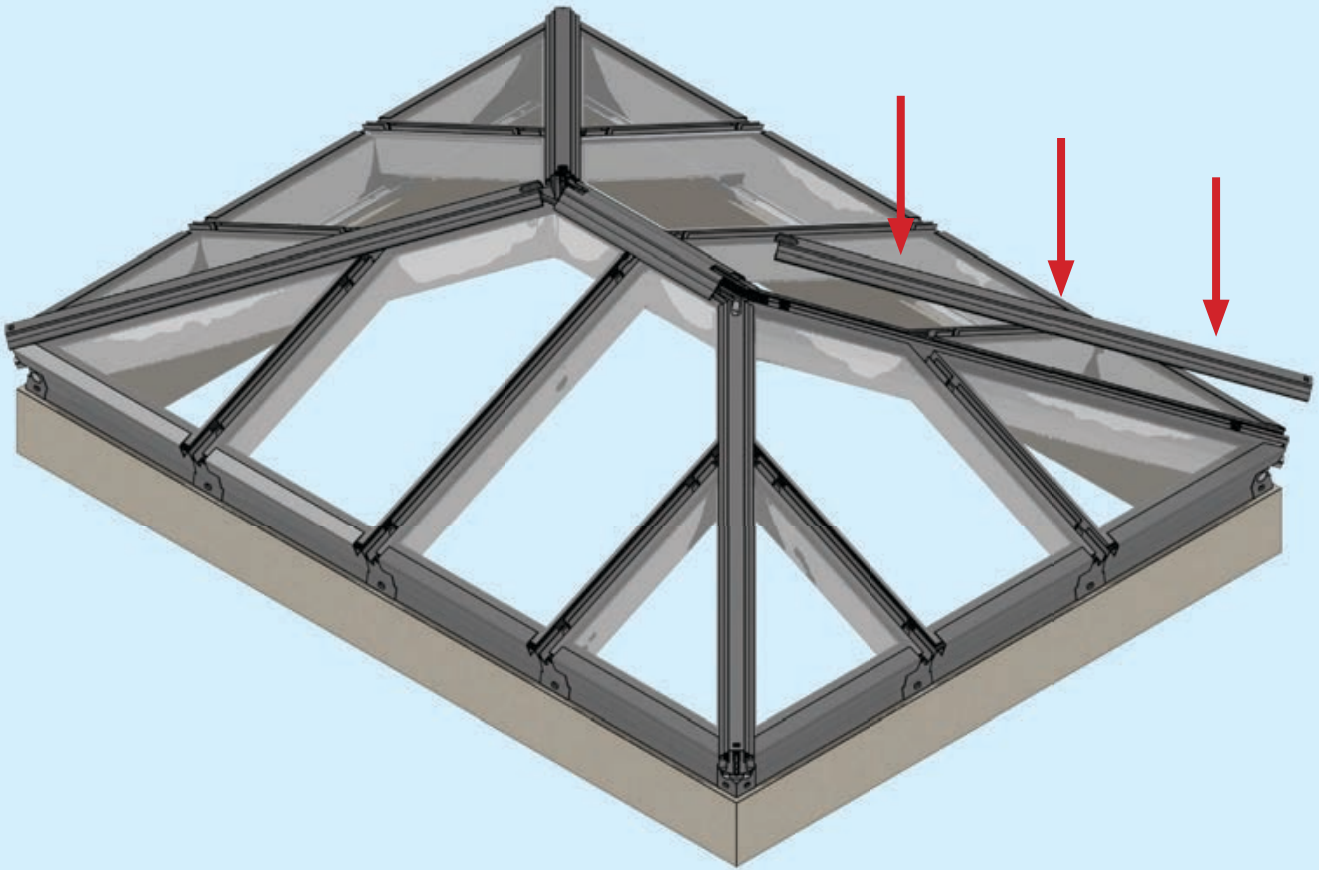

Ensure top cap lower end aligns with the lower end of hip

## RAFTER TOP CAP

# 13



- 1 Clip top caps on to rafters
- 2 Tap up into position

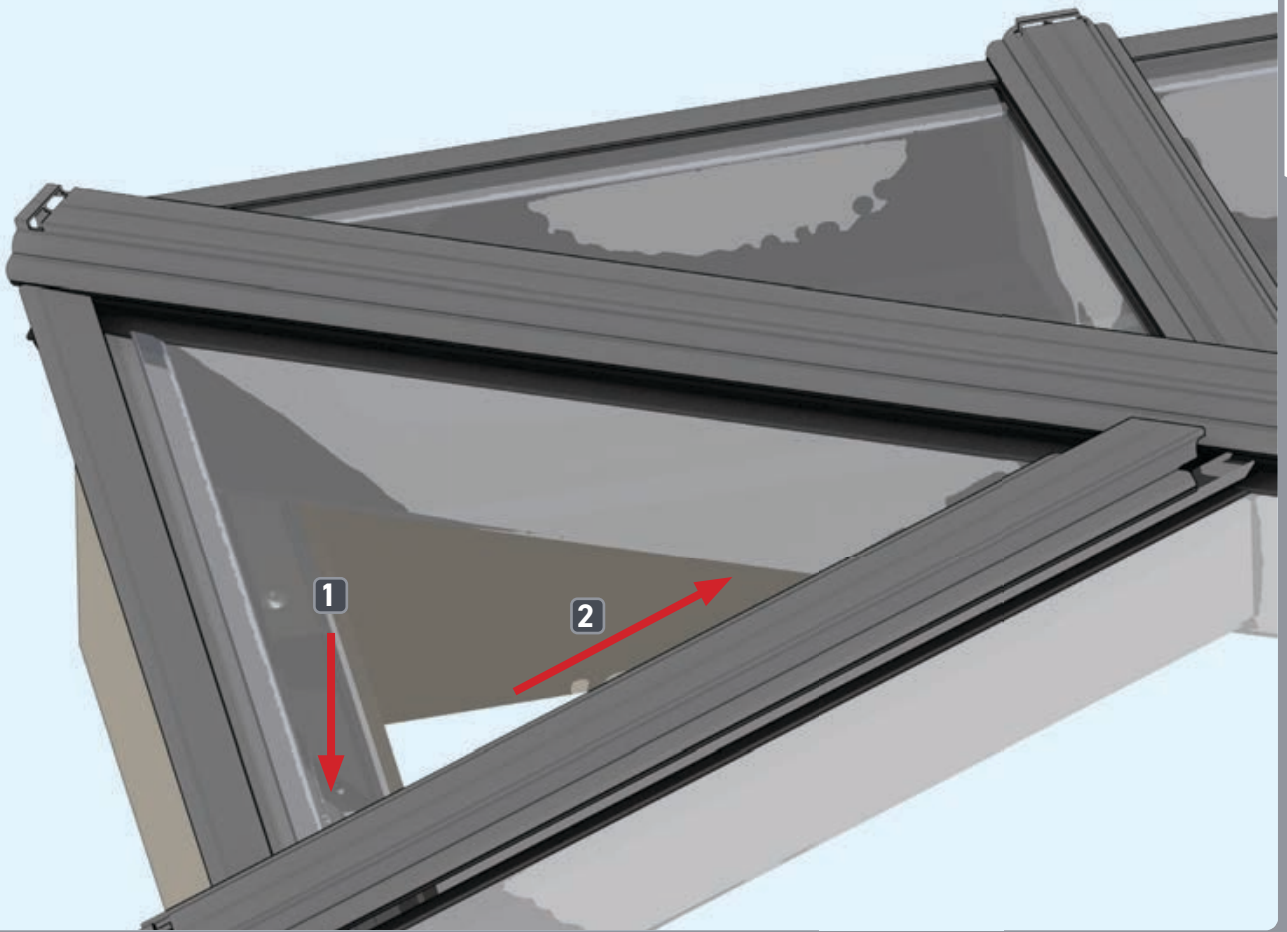

**Ensure top cap lower end aligns with lower end of rafter**



# BOSS TOP CAPS

# 14

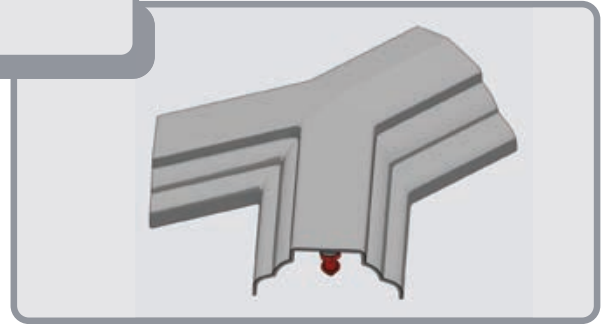

Clip in to position

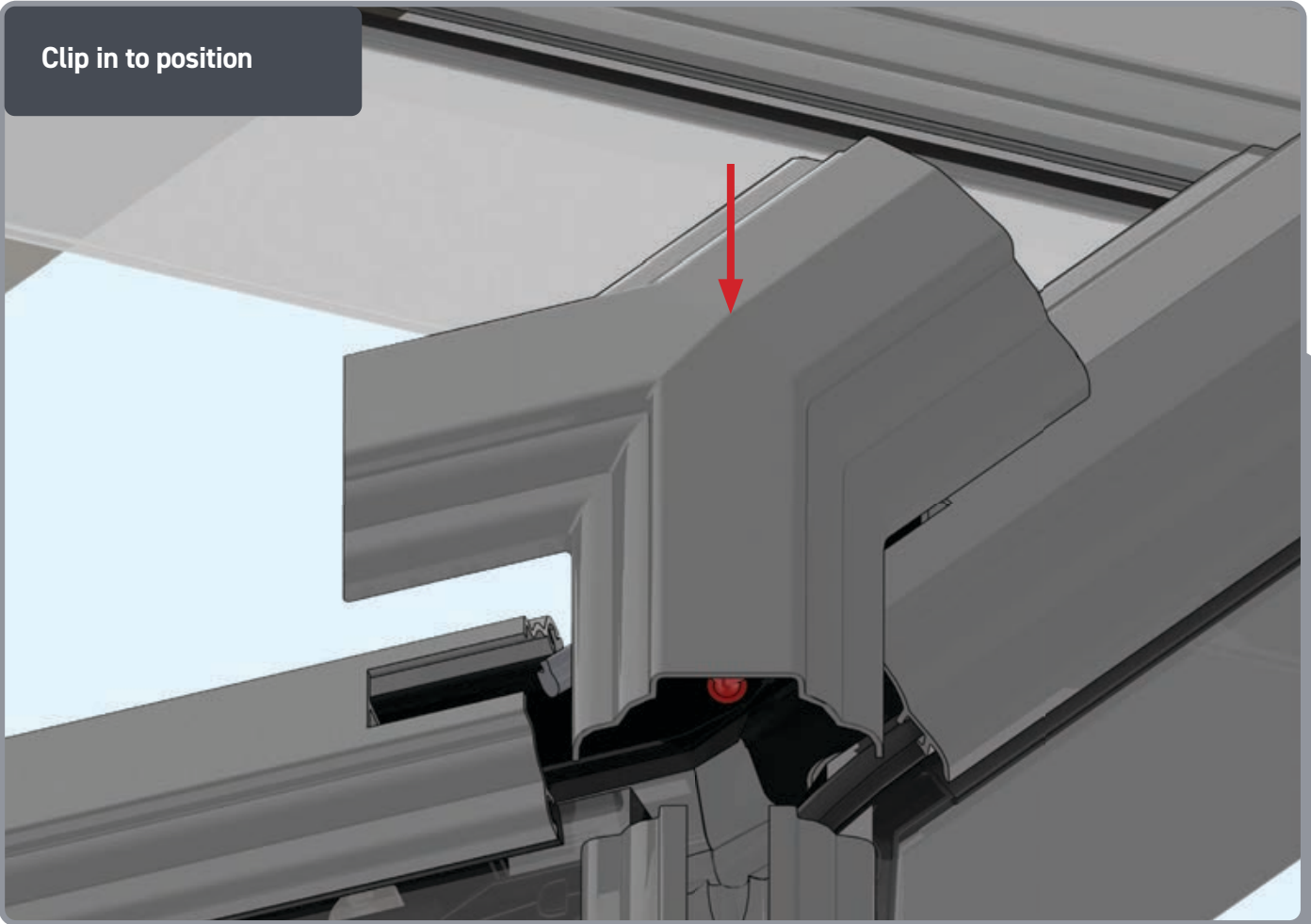

Variations

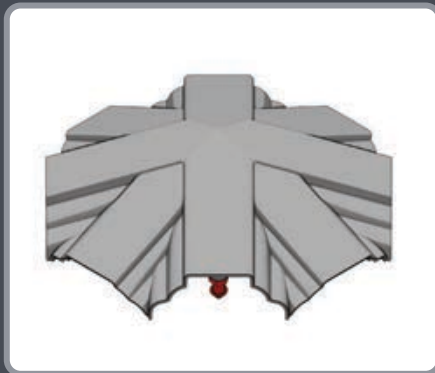

# HIP UPPER END CAPS

# 15

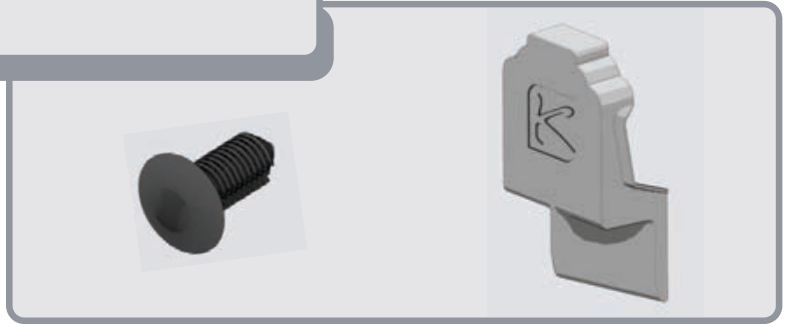

1 Fit fir tree clips to end caps



2 Push end caps onto ends of hips

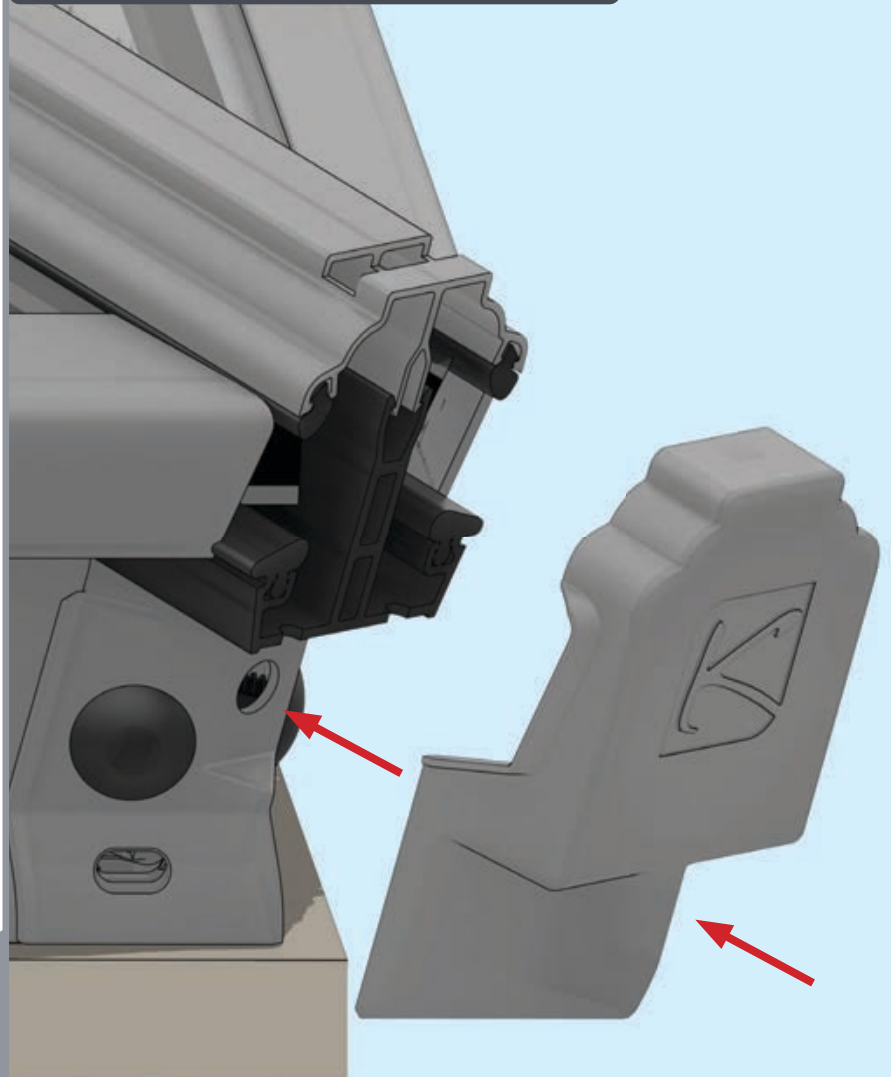

16

## RAFTER UPPER END CAPS

# 16



1 Fit fir tree clips to end caps

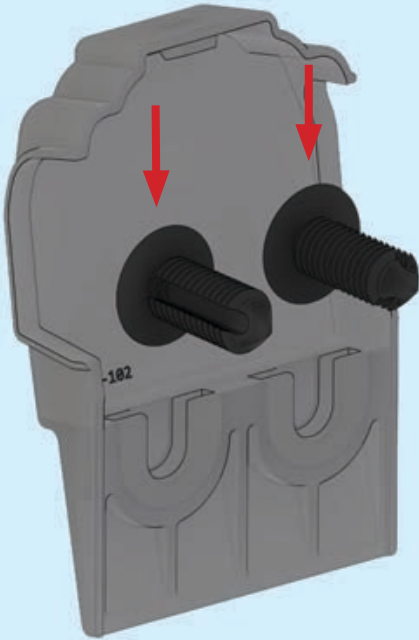

2 Push end caps onto ends of rafters

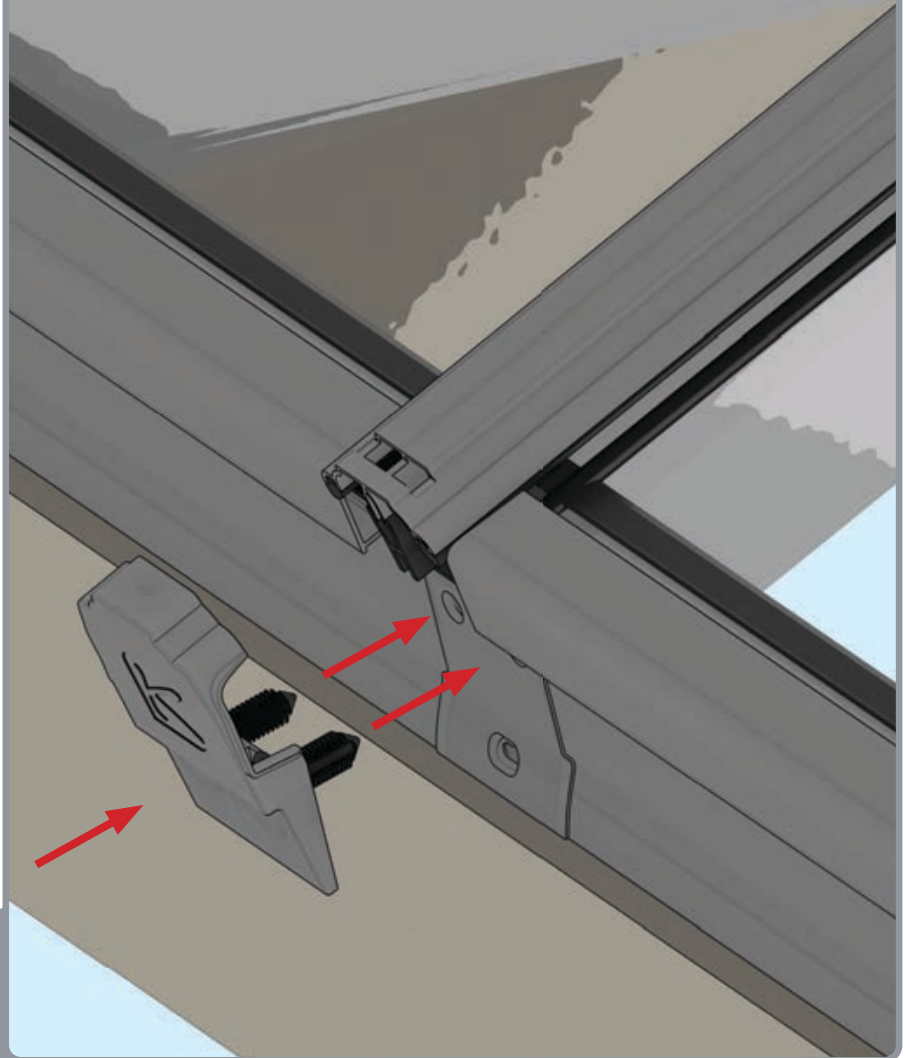

# COMPONENTS LIST



RAFTER RIDGE LUG  
**KLC-100**



RAFTER EAVES LUG  
**KLC-101**



RAFTER OUTER  
END CAP  
**KLC-102**



RAFTER INNER  
END CAP  
**KLC-103**



HIP OUTER END  
CAP  
**KLC-105**



HIP INNER  
ENDCAP  
**KLC-106**



HIP EAVES  
LUG  
**KLC-107**



2 WAY BOSS  
TOP CAP  
**KLC-108**



2 WAY BOSS TOP CAP  
FOR FINIAL  
**KLC-108/F**



3 WAY BOSS TOP CAP  
**KLC-109**



3 WAY BOSS TOP CAP  
FOR FINIAL  
**KLC-109/F**



BOSS TOP  
CAP PIN  
**KLC-110**



EAVES BEAM CORNER  
BRACKET  
**KLC-111**



ISOLATING  
COLLAR  
**KLC-112**



TWO WAY  
END BOSS  
**KLC-113**



THREE WAY  
END BOSS  
**KLC-114**



JACK RAFTER LUG LEFT  
**KLC-115**



JACK RAFTER LUG  
RIGHT  
**KLC-116**



BALL FINIAL  
**KLC-117**



B2B FOUR WAY  
BOSS  
**KLC-119**



B2B EIGHT WAY BOSS  
**KLC-120**



B2B FOUR WAY BOSS  
TOP CAP  
**KLC-121**



B2B FOUR WAY BOSS  
TOP CAP FOR FINIAL  
**KLC-121/F**



B2B EIGHT WAY BOSS  
TOP CAP  
**KLC-122**



B2B EIGHT WAY BOSS  
TOP CAP FOR FINIAL  
**KLC-122/F**



RAFTER SUPPORT  
BLOCK  
**KLC-123**



CHIMNEY  
NUT M8  
**KLF-300**



EAVES BEAM  
SCREW  
**KLF-301**



BOLT M8 X 70  
**KLF-303**



TAPERED  
WASHER M8  
**KLF-304**



BOLT M8 X 60  
**KLF-305**



FIR TREE CLIP  
**KLF-306**



BOLT M8 X 20  
**KLF-307**



SERRATED  
FLANGE NUT M8  
**KLF-311**



TIE WRAP  
**KLF-315**



EAVES BEAM / T-BAR  
QLON GASKET  
**KLG-200**



TOP CAP QLON  
GASKET  
**KLG-201**



BOSS CENTRAL  
GASKET W/CENTER  
RAFTER **KLG-202**



BOSS CENTRAL  
GASKET  
**KLG-203**



BOSS LEFT  
GASKET  
**KLG-204**



BOSS RIGHT  
GASKET  
**KLG-205**



HEX TOOL  
**KLT-01**

# COMPONENTS LIST

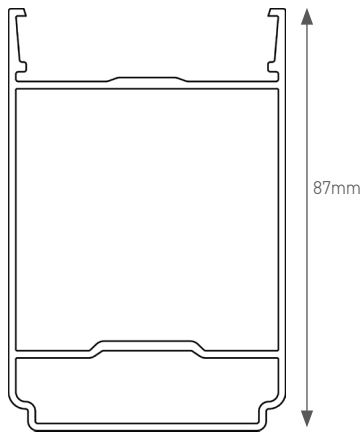

RIDGE BODY  
KLP-01

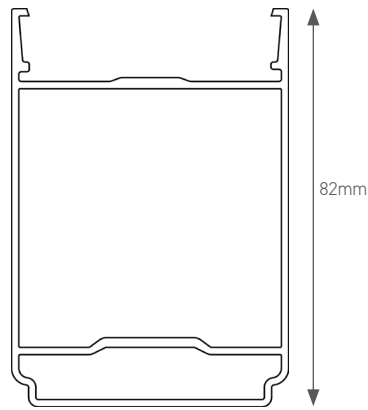

HIP BODY  
KLP-02

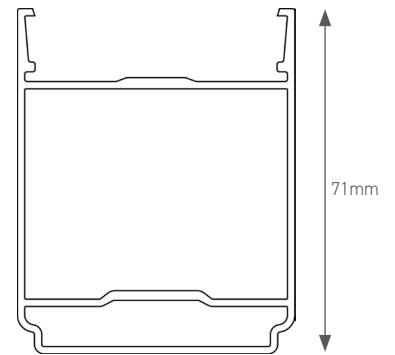

RAFTER BODY  
KLP-03

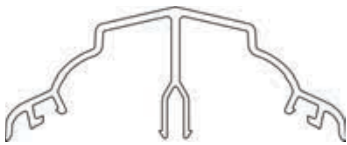

RIDGE TOP CAP  
KLP-06

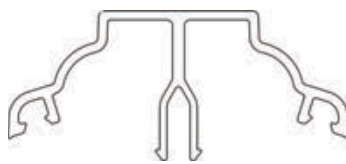

HIP TOP CAP  
KLP-07

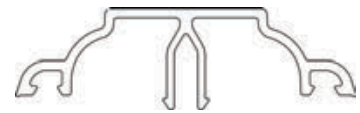

RAFTER TOP CAP  
KLP-08

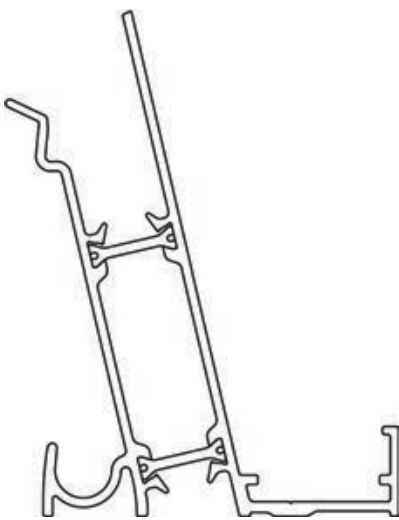

EAVES BEAM  
KLP-05

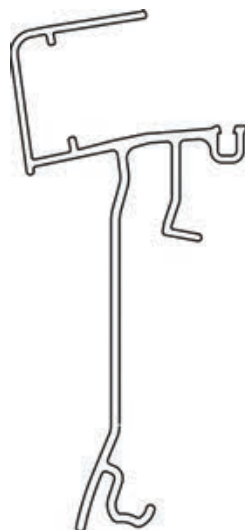

GLASS RETAINER  
KLP-04

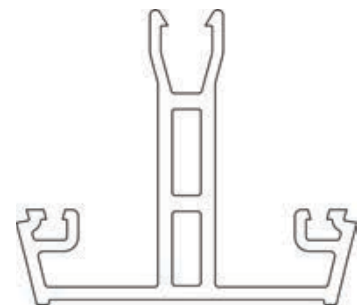

THERMAL T BAR  
KLP-09



**0800 002 9033 / 0330 111 9033**

**open 7 days a week - 9am - 8pm**

**[www.diyupvdoors.co.uk](http://www.diyupvdoors.co.uk)**

Trading online since 2013